

T12 soldering tip driver

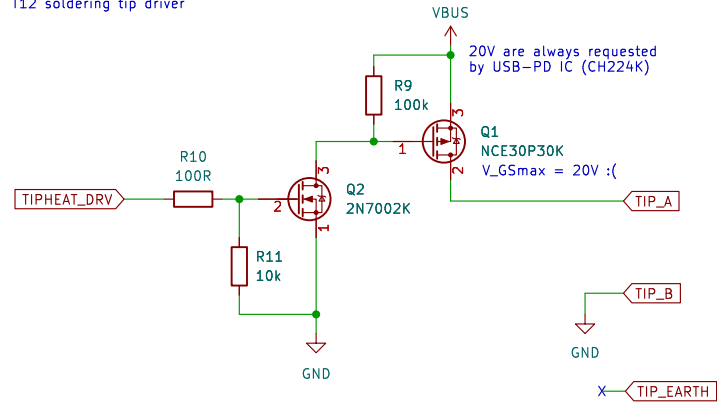

T12 soldering tip temperature measurement

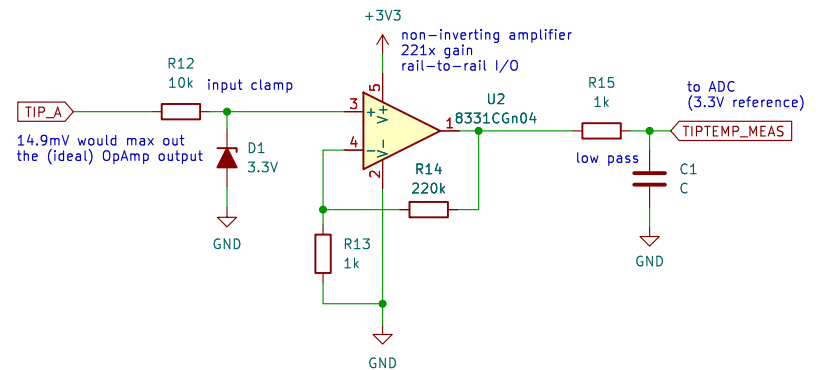

Omitted parts: USB-PD IC, 3.3V buck regulator, OLED circuit, non-populated PA0 circuit

reverse engineered by spezifisch <spezifisch23@proton.me>

Sheet: /
File: pen_solder_v3.kicad_sch

Title: PEN SOLDER V3 2023-02-02

Size: A4
KiCad E.D.A. kicad 7.0.6

Date:

Rev:
Id: 1/1